

E-Tool 7 Drawer

Rugged Deployed Mobile Manager (Managed or Passive Network Switch)

Description

The Tracewell E-Tool Mobile Manager is the answer to Defense and Commercial Industries' initiative to implement and field electronic media platforms tools reducing the reliance on traditional paper bound manuals, providing a reliable and secure path for Interactive Electronic Tech Manuals (IETM). Tracewell Systems' objective is to provide a storage, transport and charging system with a single point LAN connection for a wide variety of E-Tool platforms that is lightweight and rugged, enabling worldwide use and operation in harsh environments.

Features

- 7 drawers support 7 E-Tools
- Each drawer has 1 power outlet and 1 Ethernet connection
- Single point locking mechanism for all trays
- Each drawer has individually re-settable fused drawers
- Power and fan monitoring with LED displays
- Rugged laser stitch-welded corrugated construction
- Water, chemical and abrasion resistant
- E-Tools can be mechanically secured in each drawer for deployment
- Operates at 85 - 264VAC at 47 - 440Hz
- Locking casters with quick disconnect and storage
- Temperature controlled fans for quiet operation
- Drawers can be locked to prevent theft
- Equipped with a Juniper SRX-100 managed Ethernet switch, Netgear passive Ethernet switch, or fully wired with no switch installed
- Single-point Ethernet connection
- Operating temperature 0°C to +50°C
- Stackable with interlocking safety pins
- Filtered air cooling for each drawer
- Serial port for additional diagnostics
- COTS components
- 5 Year warranty optional
- Rugged, safe and secure laptop storage



Description

E-Tool Mobile Manager,
7 Drawer, Rugged Deployed Managed
or Passive Network Switch

Front (sealed doors installed)

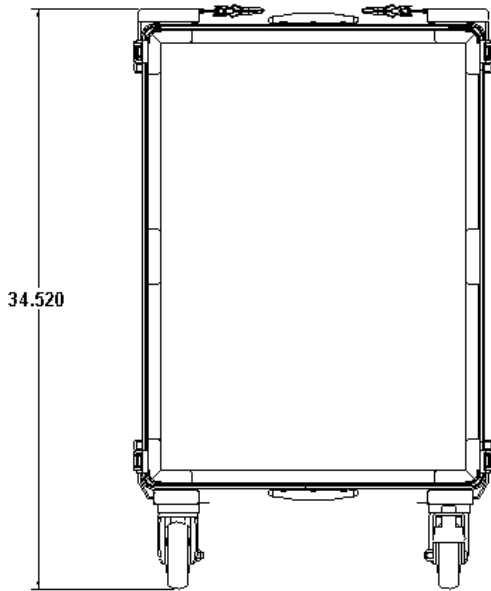

Top

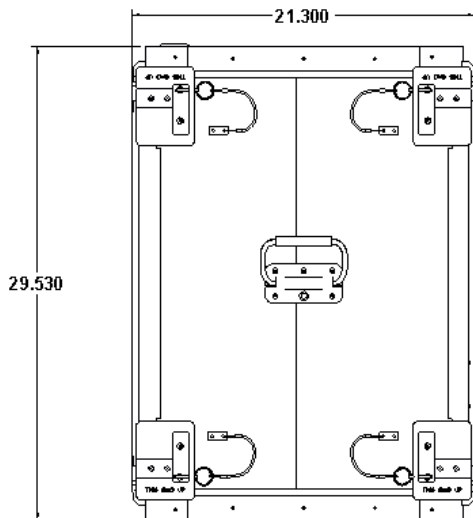

Specifications

- Operating temperature: 0°C to +50°C
- Dimensions: H 34.6" x W 21.4" x D 29.6"
- Universal input power: 85-264VAC, 47-440Hz, 15A Max Single Phase
- Rugged enclosure design incorporates spring loaded recessed handles and rugged, abrasion & corrosive resistant coating
- Weight: ~ 125 lbs. (empty)

System Monitors

- Fan Fail
- Fan Speed
- Temperature
- Input Power
- Current Draw

Rack System

- 7 E-Tool charging/LAN interface trays
- Variable speed fans provide cooling to each tray
- Pre-wired with CAT-5 Ethernet cable
- Washable air filters

Common Rugged Docking Drawers

- 11" Clearance when fully extended
- Drawer dimensions: H 3.25" x W 15.0 x D 16.4"
- Opens to provide easy access to E-Tools
- Single-point locking mechanism locks all drawers
- Adjustable & secure strapping system secures E-Tools for shipment

© 2011-2013 Tracewell Systems, Inc. All rights reserved.

Tracewell Systems, Inc. reserves the right to make changes without notice.
All brand or product names may be trademarks or registered trademarks of their respective holders.

PART NUMBERS:

7 Drawer, Rugged, Deployed, Passive: 510-1167-F01-00
7 Drawer, Rugged, Deployed, Managed: 510-1167-F21-00
7 Drawer, Rugged, Deployed, No Switch: 510-1167-F40-00