

E-Tool Mobile Manager

7 Drawer - Rugged Deployed - Passive

Description:

The Tracewell E-Tool Mobile Manager is the answer to Defense and Commercial Industries' initiative to implement and field electronic media platforms tools reducing the reliance on traditional paper bound manuals, Interactive Electronic Tech Manuals IETM. Tracewell Systems' objective is to provide a storage, transport and charging system with a single point LAN connection for a wide variety of E-Tool platforms that is lightweight and rugged, enabling worldwide use and operation in harsh environments.



Features:

- 7 drawers support 7 E-Tools
- Each drawer has 1 power outlets and 1 Ethernet connection
- Single point locking mechanism for all trays
- Each drawer has individually re-settable fused drawers
- Power, fan and load monitoring with LED displays
- Rugged laser stitch-welded corrugated construction
- Water, chemical and abrasion resistant
- E-Tools can be mechanically secured in each drawer for deployment
- Operates at 90 - 264VAC at 47 - 440Hz
- Locking casters with quick disconnect and storage
- Temperature controlled fans for quiet operation
- Drawers can be locked to prevent theft
- Single-point Ethernet connection
- Operating temperature 0°C to +50°C
- Stackable with interlocking safety pins
- Filtered air cooling for each drawer
- Power load monitoring
- Optional on-board server
- Serial port for additional diagnostics
- COTS components
- 5 Year warranty optional
- Rugged, safe and secure laptop storage

Ordering Information:

Tracewell Part number
510-1167-F00-00

Description

E-Tool Mobile Manager, 7 Drawer,
Rugged Deployed, Passive

System Specifications

- Operating temperature: 0°C to +50°C
- Dimensions: 30"(L) x 21.5"(W) x 29"(H)
- Universal input power: 90-264VAC, 47-440Hz, 15A Max Single Phase
- Rugged enclosure design incorporates spring loaded recessed handles and rugged, abrasion & corrosive resistant coating
- Weight: ~125 lbs. (empty)

System Monitors

- Fan Fail
- Fan Speed
- Temperature
- Input Power
- Current Draw

Rack System

- 7 E-Tool charging/LAN interface trays
- Variable speed fans provide cooling to each tray
- Pre-wired for CAT5
- Washable air filters

Common Rugged Docking Trays

- 11" Clearance when fully extended
- Tray dimensions: 18"(L) x 17"(W) x 3.3"(H)
- Opens to provide easy access to E-Tools
- Single-point locking mechanism locks all trays
- Adjustable & secure strapping system secures E-Tools for shipment

Options

- Encrypted wireless
- CAC reader
- Variety of electrical and mechanical locking features
- RFID
- Software drawer asset administration

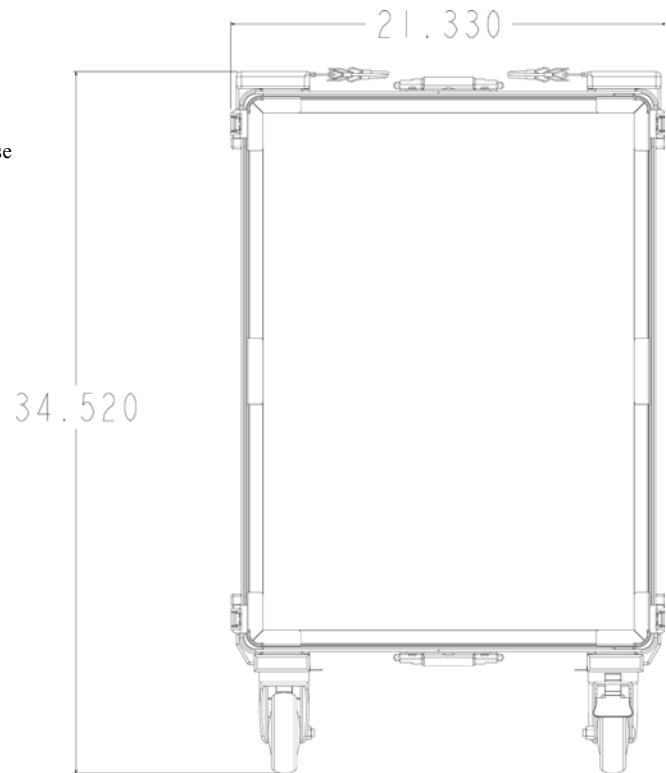

FRONT (sealed doors installed)

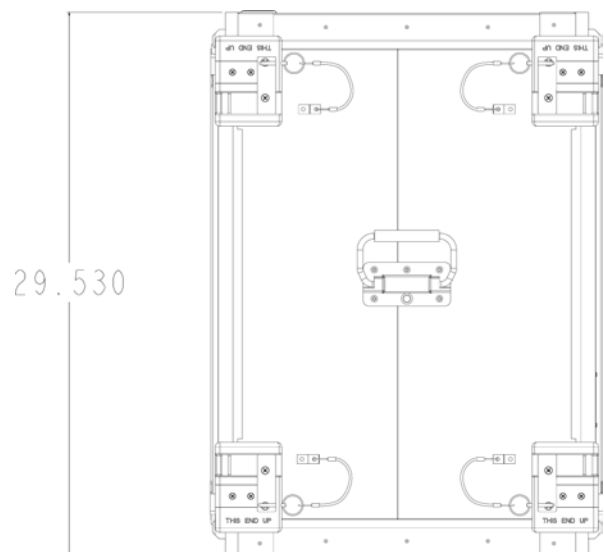

TOP

© Copyright Tracewell Systems, Inc. 2009

Tracewell Systems, Inc. reserves the right to make changes without notice. All brand or product names may be trademarks or registered trademarks of their respective holders.

Please consult Tracewell Systems for any special or custom requirements.