

T-Frame™ for CompactPCI™ H.110

8-Slot CompactPCI™ H.110 Telephony Test and Development System

Description

Tracewell Systems offers the ideal test and development platform for CompactPCI computer telephony applications. The T-Frame™ for CompactPCI H.110 integrates a time division multiplexing (TDM) bus along with the cPCI bus to support real-time voice or signal data. By combining the telephony features of H.110 with unique mechanical design and a host of convenient features, T-Frame™ is the perfect tool for CompactPCI H.110 applications.

T-Frame's patented open-frame design eliminates the need for performance robbing extender cards by providing unrestricted access to installed boards. T-Frame™ includes comprehensive monitoring of all backplane voltages, current and exhaust air temperature. A front panel interface displays these monitor outputs and includes temperature, fan speed, and voltage control, including +5 and +3.3 volt margining. The 64-bit cPCI 8-slot backplane includes an H.110 TDM bus on P4 and additional telephony I/O on P5 for all peripheral slots. System slot excludes the H.110 bus to allow feed through I/O and segment bridging through P3 - P5 connectors. The left-justified System slot provides full access to the component side of installed boards. Two power options are available including single or dual 350 watt plugging power supplies, allowing hot swap power simulation, N+1, or 700 watt operation. Power supplies may be installed in either the front or rear cardcage, further improving accessibility. Fans are adjustable for full or half speed and automatically turn-off when not in use to reduce noise. The T-Frame's steel and aluminum construction make it rugged yet easily portable. Tracewell's rigid steel cardcage eliminates the flex common to conventional extruded rail designs and is fully IEEE 1101.10/11 compliant. The rear I/O cardcage is adjustable for a wide range of board depths. Other conveniences include a tilt base, removable side access covers, recessed carrying handles, and internal 3.5" peripheral bay.

T-Frame™ for CompactPCI H.110 reduces design cycles by providing the user unmatched accessibility, measurement and control for any CompactPCI computer telephony development.



T-Frame™ US Patent 5,416,427

Features

- Patented open-frame design eliminates extender boards
- Built-in voltage, current and temperature monitoring
- Front panel controls for margining +5 and +3.3 volts
- Hot-Swap and H.110 compliant backplane
- 350W, N+1, or 700W operation
- Plugging power supplies with PFC and hot-swap
- IEEE 1101.10/11 compliant steel subracks eliminate flex
- Convenient tilt base and removable side panels
- Adjustable rear cardcage fits 60, 80 and 100mm boards



ISO 9001
certified

Physical

Construction:	Aluminum sheet, 5052-H32 alloy; major components: sides (0.250"), top and bottom covers (0.062"), base (0.188") Steel sheet, ASTM A366; major components: front and rear cardcages (0.060")
Plastics:	Aluminum Extrusion, 6101-T6 alloy; cardcage front profile Cardguide, snap-in, 0.062" pcb, white nylon, UL-94V-2 material; Cardguide entry, snap-in, 0.062" pcb, neutral nylon, UL-94V-0 flame rated material; Adjustment knobs, black polycarbonate, UL-94HB flame rated material; Tinted view windows, gray polycarbonate, UL-94HB material
Cardcage:	<i>Front:</i> 6U x 160mm, 8 slots, IEEE 1101.10 <i>Rear:</i> 6U x 80mm, 8 slots, IEEE 1101.11, adjustable for 60, 80, and 100mm boards
Dimensions:	15.60"D (396 mm), 14.37"W (365 mm), 16.83"H (428 mm)
Weight:	34 lbs. (74.8 kg) with one power supply (PS1); 37.5 lbs. (82.5 kg) with two power supplies (PS2)
Finish:	Textured paint, T-Frame light gray per Sherwin Williams F63TXA0819; all exterior surfaces All other all aluminum is brushed gold chromate per MIL-STD 5541, steel is bright zinc plate
Accessories:	Hardware kit provided which includes (8) +5.0 (brilliant blue) and +3.3V (cadmium yellow) backplane I/O keys, (2) I/O jumpers, and (1) drive power harness; Four removable side panels provided

Backplane

Bus structure:	cPCI 32/64 bit with H.110 TDM bus; system slot left
Assembly:	SMT/press-fit assembly
Layer count:	10 layers
Control:	PRST#, DEG#, FAL#, return and remote sense (+5, +3.3, +/-12VDC)
PCB construction:	FR4 epoxy-glass laminate, multilayer, all-stripline, SMOBC, silkscreen on two sides, 1oz. copper signal and power planes minimum, UL 94V-0, 0.150" (3.8 mm) thickness
Impedance:	65 Ohms nominal on all signal lines, non-loaded pcb
Termination:	None provided
Decoupling:	SMT decoupling per PICMG 2.0 R3.0
Rear shrouds:	Extended 16mm tails and AB compatible shrouds on all P3 – P5 connectors
DC distribution:	Screw terminals for +5, +3.3, return and V I/O (35A rating per terminal), 20 position ATX for +5, +3.3, +/-12VDC, and return (9A rating per pin), 0.250 spade terminals for +/-12Vdc (15A rating per terminal)
Compliance:	PICMG 2.0 R3.0, hot swap compatible per PICMG 2.1, H.110 per PICMG 2.5

Power †

Option code PS1:	T-Frame equipped with a single 350W 6U DIN power supply
Option code PS2:	T-Frame equipped with dual 350W 6U DIN power supplies
Total output:	300W 90 – 105VAC; 350W 105 – 264VAC; maximum for all outputs combined
Operation:	Single power supply may be hot-plugged without effecting normal system operation (PS2)
Input:	90 – 264VAC, universal input
Frequency:	47 – 63 Hz
Efficiency:	70% typical (65% min. at 90VAC)
Power factor:	0.99 typical
Input current:	6A maximum
Inrush current:	40A maximum
Hold-up time:	20 ms minimum
DC outputs:	+5.0V/ 40A, +3.3V/ 25A, +12V/ 9A, -12V/ 2A
Output adjustment:	+/-10% nominal on +5 and +3.3V only
Ripple/Noise:	50mV maximum, all outputs
Load requirement:	None required
Remote sense:	All outputs, 250mV maximum compensation
Cooling:	15cfm/400lfm minimum airflow required through power supply fins; airflow provided by cardcage
Accessibility:	DIN power supplies install in cardcage in any two of three power slots; (2) front, (1) rear

Cooling

Airflow:	Bottom intake, top exhaust, pressurized; cPCI boards and power supplies cooled independently
Fans:	(3) 130cfm, high pressure tube-axial, 12VDC, one positioned below 8 slot front cPCI cardcage, one below front power slots, and below rear power slot; (1) 93cfm, tube-axial, 12VDC, also evacuates air above front power slots
Adjustment††:	All fans adjustable for 50% or full speed operation; front panel switch control cPCI cardcage fan, power supply fan speeds are controlled by switch S2 on the power backplane.

Storage

Peripheral support:	(1) 3.5" x 1" device
Power harness:	(1) 4-pin IDC, AMP 1-480424-0 or equivalent; (1) 4-pin IE (mini), AMP 171822-4 or equivalent
Cooling:	Convection
Accessibility:	Rear removable tray, tool accessible

Control and Input

Switches:	<i>Front panel:</i> margin control for +5, +3.3VDC, voltage select (rotary); Voltage/ °C, fan speed control (pushbutton, latching); reset control (pushbutton, momentary) <i>Rear panel:</i> Power supply disable/inhibit control (SW1), power supply fan speed (50% or full; SW2), AC power switch (rocker), AC circuit breaker (pushbutton, latching)
Power input:	Rear panel AC inlet connector (IEC320), (7' line cord provided)
Circuit protection:	Rear panel single pole magnetic circuit breaker, 12A (pushbutton, latching)

Monitoring

Interface:	Two front panel LCD numeric displays and LED indicators
Functions:	Backplane DC voltage and current measurement for +5, +3.3, +/-12VDC (front panel, user selectable); Exhaust air temperature over front cPCI card slots (°C, user selectable, rear assess slide probe); Margin control provides +/-10% adjustment of +5 and +3.3VDC (front panel user selectable); Backplane reset control and indicator (referenced to backplane BRST*); Power-on LED indicator (referenced to power supply +5VDC)
Outputs:	DC voltage/current output displayed on (2) front panel green LCDs; Exhaust air temperature display on the Voltage LCD when Voltage/ °C switch is depressed; Power-on LED indicator illuminates green when power supply +5VDC is present; Margin controlled voltages display on Voltage LCD when Voltage selector is set to +5 or +3.3VDC; Reset LED illuminates red whenever backplane reset (BRST*) is asserted
Tolerance:	DC voltage measurement within 1%; current measurement within 3%; temperature within 3°C (Tolerances assume a 20-minute warm-up period for chassis and installed components)

Environmental

Temperature:	0 – 50°C operating with specified airflow -20 – 70°C non-operating
Shock/Vibration:	Basic transportation per ASTM 0775
Humidity:	5 – 95% non-condensing at 40°C operating 0 – 95% non-operating
Acoustic:	<55 dBA maximum, measured 1 meter from all surfaces)

Agency Compliance †††

Safety/Emissions:	Available for the power supply only Consult factory for detail
--------------------------	---

Warranty

	1 year limited warranty
--	-------------------------

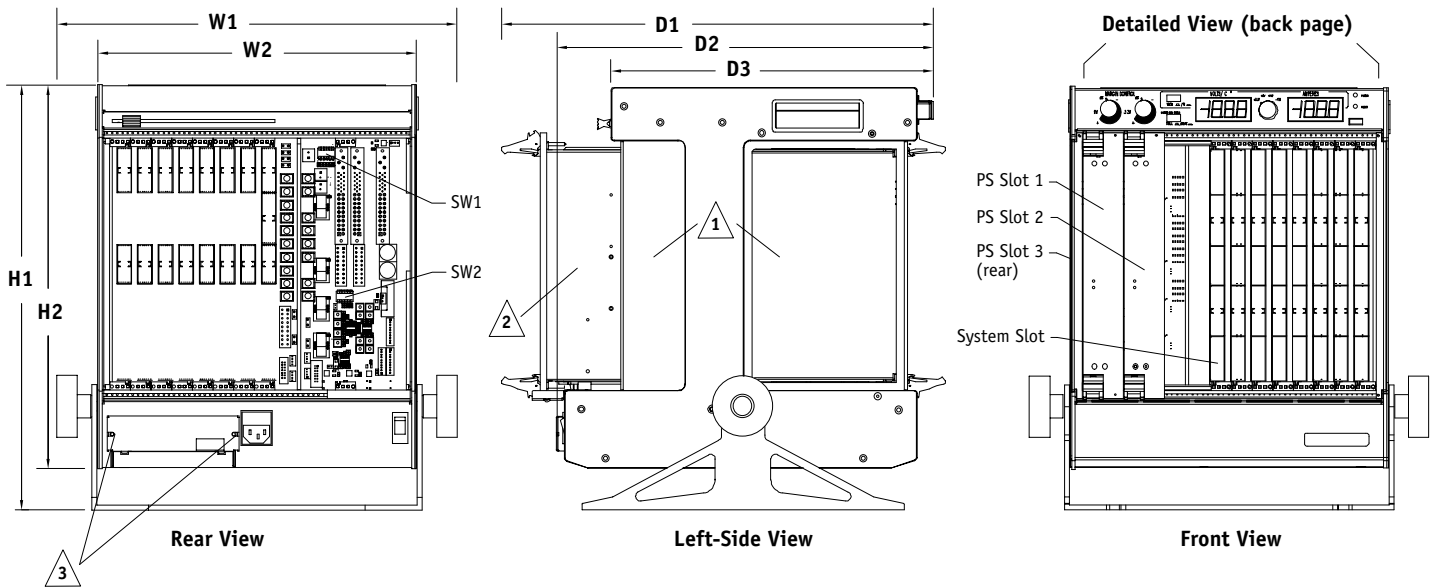

Power Supply Configuration

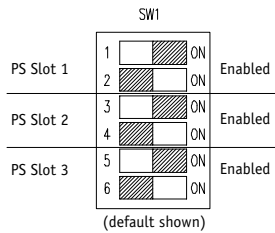

Power Supply Fan Speed

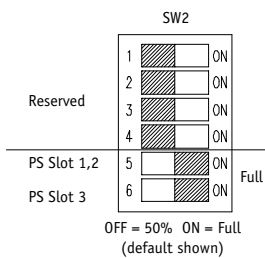

Rear Subrack Adjustment

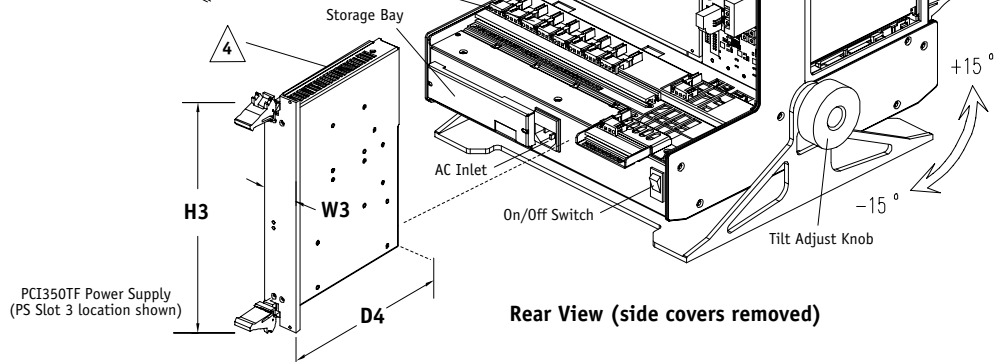
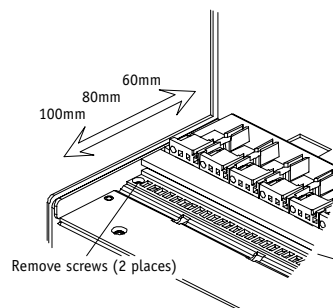

Dimensions:

D1: 17.10" (435 mm)	W1: 15.08" (383 mm)	H1: 16.37" (416 mm)
D2: 14.62" (371 mm)	W2: 12.34" (313mm)	H2: 14.77" (375 mm)
D3: 12.55" (319 mm)	W3: 1.60" (41 mm)	H2: 10.31" (262 mm)
D4: 6.77" (172 mm)		

NOTES:

- 1 Removeable side covers installed (4 places)
- 2 Power supply shown in PS Slot 3 position
- 3 Storage bay removes with 2 screws
- 4 CAUTION!! Power supplies carry hazardous voltage

Detailed View of Front Panel

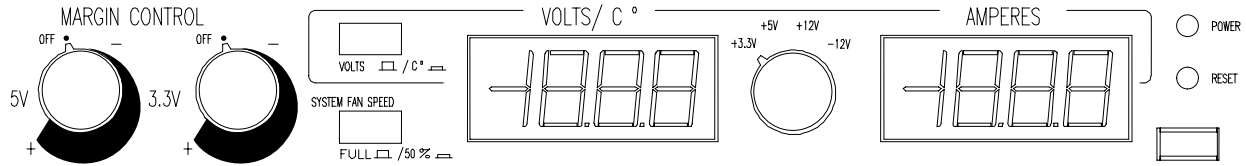

Ordering Information

T-Frame™ for CompactPCI H.110 includes chassis, backplane, power supply, storage bay, and monitoring and is available in the following standard configurations:

Part number	Description
580-6011-F00-00	T-Frame for CompactPCI H.110 with single 350W AC power supply (PS1)
580-6012-F00-00	T-Frame for CompactPCI H.110 with dual 350W AC power supplies (PS2)

Accessories

014-6001-001-0P	Shielded single-slot filler panel, 6U X 4T; installs in vacant slots
106-1001-099-01	Non-shielded single-slot filler panel, 6U X 4T; installs in vacant slots
110-1171-099-01	Subrack air block, single slot, 1101.10; snaps into a vacant slot to block airflow

Notes

- † This product is designed for operation only with Tracewell PCI350 power supplies. Operation is limited to a maximum of two power supplies, totaling 700 watts.
- †† IMPORTANT all fans must be operated in Full speed setting for output power levels greater than 100 watts.
- ††† As an option, Tracewell Systems can evaluate agency compliance for the customer's specific integrated product. Consult factory for more details

visit our website at:
www.tracewellsystems.com

or call toll free: 1.800.848.4525