

E-Tool 14 Drawer Rugged Deployed Mobile Manager (Managed)

Description

The Tracewell E-Tool Mobile Manager is the answer to Defense and Commercial Industries' initiative to implement and field electronic media platform tools reducing the reliance on traditional paper bound manuals, providing a reliable and secure path for Interactive Electronic Tech Manuals IETM. Tracewell Systems' objective is to provide a storage, transport and charging system with a single point LAN connection for a wide variety of E-Tool platforms that is lightweight and rugged, enabling worldwide use and operation in harsh environments.

Features

- Charges up to 14 Laptop Computers Simultaneously
- Network Connections and AC Power Provided to Each Drawer
- Secures E-Tools for Transport
- Managed Ethernet Switch

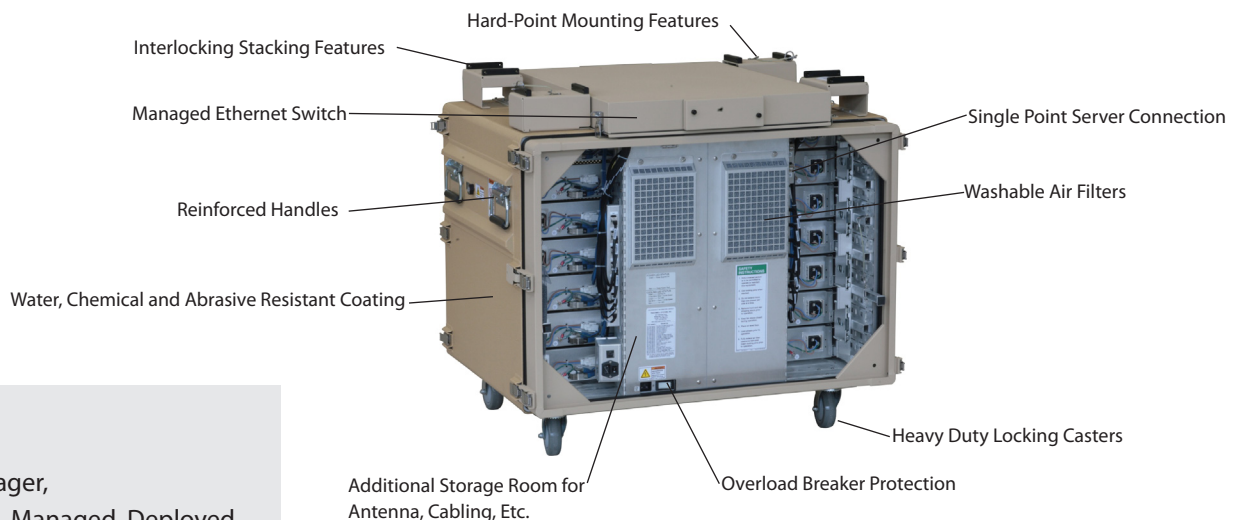

Description

E-Tool Mobile Manager,
14 Drawer, Rugged, Managed, Deployed

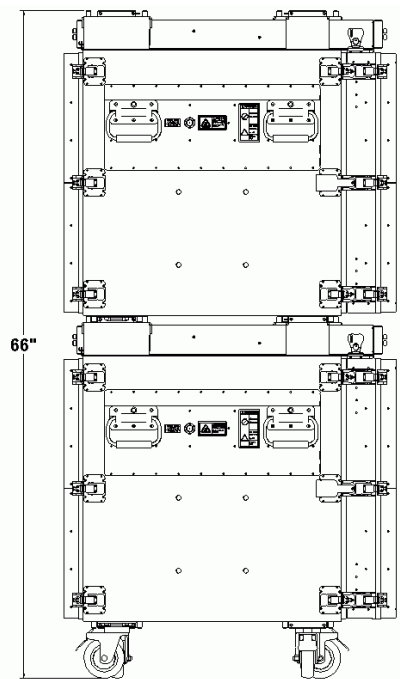
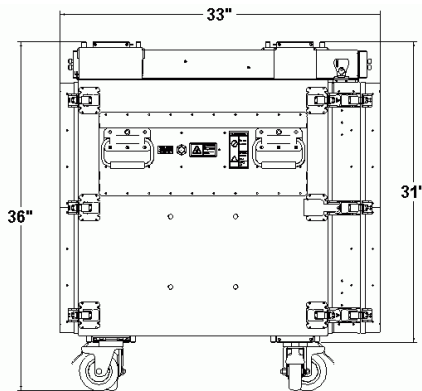
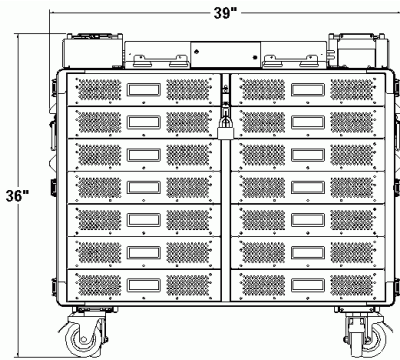

Specifications

- Operating Temperature: 0C - +50C
- Cabinet dimension, with casters: H 35.9" x W 39.1" D 32.9" (with transit covers)
without casters: H 31.0"
- Universal Input Power: 85-264 VAC, 47-440Hz, 15A Max, Single Phase
- Rugged Enclosure Design incorporates, spring loaded recessed handles and rugged, abrasion & corrosive resistant coating
- Unit equipped with a managed Ethernet switch (F31) or fully wired with no switch installed (F40)
- Weight: approx. 210lbs (empty)

System Monitors

- Fan Fail
- Fan Speed
- Temperature
- Input Power
- Current Draw

Rack System

- 14 E-Tool charging/LAN interface drawers
- Variable speed fans provide cooling to each drawer
- Pre-wired with CAT-5e cable
- Washable air filters

Power System

- Universal AC input voltage
- Transient protected, filtered AC power to each drawer

Rugged Docking Drawers

- 11" clearance when fully extended
- Drawer dimensions: H 3.25" x W 15.0" x D 16.4"
- Single point locking mechanism locks all drawers
- Adjustable & secure strapping systems secures E-Tools for shipment

© 2011-2013 Tracewell Systems, Inc. All rights reserved.

Tracewell Systems, Inc. reserves the right to make changes without notice.

All brand or product names may be trademarks or registered trademarks of their respective holders.

Doc. p/n: 095-2039-000-00 Rev. A

PART NUMBERS:

14 Drawer with Cisco Managed Switch: 510-1106-F31-00

14 Drawer with No Switch Installed: 510-1106-F40-00